



## INSTRUCTION MANUAL

VHF MARINE TRANSCEIVER

# IC-M501EURO



Icom Inc.

---

## IN CASE OF EMERGENCY

---

If your vessel requires assistance, contact other vessels and the Coast Guard by sending a distress call on channel 16.

### **USING CHANNEL 16**

#### **DISTRESS CALL PROCEDURE**

1. "MAYDAY MAYDAY MAYDAY."
2. "THIS IS ....." (name of vessel)
3. Your call sign or other indication of the vessel (AND 9-digit DSC ID if you have one).
4. "LOCATED AT ....." (your position)
5. The nature of the distress and assistance required.
6. Any other information which might facilitate the rescue.

Or, transmit your distress call using digital selective calling on channel 70 (the optional DS-100 must be installed).

### **USING DIGITAL SELECTIVE CALLING (ch 70)**

(DS-100 DSC CONTROLLER is required)

#### **DISTRESS CALL PROCEDURE**

1. Push and hold [DISTRESS] on the DS-100 for 5 sec. until you hear 5 short beeps change to one long beep.
2. Wait for an acknowledgment from a coast station.
  - Channel 16 is automatically selected.
3. Push and hold [PTT], then transmit the appropriate information as at left.



Versions of the IC-M501EURO which display the "CE" symbol on the serial number seal, comply with the essential requirements of the European Radio and Telecommunication Terminal Directive 1999/5/EC. Ⓢ This warning symbol indicates that this equipment operates in non-harmonised frequency bands and/or may be subject to licensing conditions in the country of use. Be sure to check that you have the correct version of this radio or the correct programming of this radio, to comply with national licensing requirement.

---

# INSTALLATION NOTES

---

The installation of this equipment should be made in such a manner as to respect the EC recommended electromagnetic field exposure limits (1999/519/EC).

The maximum RF power available from this device is 25 watts. The antenna should be installed as high as possible for maximum efficiency and that this installation height should be at least 5 meters above ground (or ac-

cessible) level. In the case where an antenna cannot be installed at a reasonable height, then the transmitter should neither be continuously operated for long periods if any person is within 5 meters of the antenna, nor operated at all if any person is touching the antenna.

In all cases any possible risk depends on the transmitter being activated for long periods.

(actual recommendation limits are specified as an average of 6 minutes) Normally the transmitter is not active for long periods of time. Some radio licenses will require that a timer circuit automatically cuts the transmitter after 1–2 minutes etc.

Similarly some types of transmitter, SSB, CW, AM, etc. have a lower 'average' output power and the perceived risk is even lower.

---

# TABLE OF CONTENTS

---

<b>1 OPERATING RULES</b> .....	1	■ Operation .....	11	■ Cleaning .....	17
<b>2 PANEL DESCRIPTION</b> .....	2–5	<b>5 SCAN OPERATIONS</b> .....	12–13	■ Connections .....	18
■ Panel description .....	2	■ Scan types .....	12	■ Mounting the transceiver .....	19
■ Function display .....	4	■ Setting tag channels .....	13	■ Optional unit installation .....	21
■ Microphone .....	5	■ Starting a scan .....	13	■ Dimensions .....	20
<b>3 BASIC OPERATION</b> .....	6–10	<b>6 SET MODE</b> .....	14–16	<b>8 TROUBLESHOOTING</b> .....	23
■ Channel selection .....	6	■ Set mode programming .....	14	<b>9 CHANNEL LIST</b> .....	24
■ Receiving and transmitting .....	8	■ Set mode items .....	15	<b>10 SPECIFICATIONS AND OPTIONS</b> ...	25
■ Call channel programming .....	9	<b>7 CONNECTIONS AND</b>		■ Specifications .....	25
■ Channel names .....	9	<b>MAINTENANCE</b> .....	17–22	■ Options .....	25
■ Optional voice scrambler operation ..	10	■ Unpacking .....	17		
<b>4 DUALWATCH/TRI-WATCH</b> .....	11	■ Antenna .....	17		
■ Description .....	11	■ Fuse replacement .....	17		

## MB-75 TEMPLATE

---

## IMPORTANT

---

**READ ALL INSTRUCTIONS** carefully and completely before using the transceiver.

**SAVE THIS INSTRUCTION MANUAL** — This instruction manual contains important operating instructions for the IC-M501EURO.

---

## CAUTIONS

---

**⚠ WARNING! NEVER** connect the transceiver to an AC outlet. This may pose a fire hazard or result in an electric shock.

**NEVER** connect the transceiver to a power source of more than 16 V DC or using reverse polarity. This will ruin the transceiver.

**NEVER** cut the DC power cable between the DC plug and fuse holder. If an incorrect connection is made after cutting, the transceiver may be damaged.

**NEVER** place the transceiver where normal operation of the vehicle may be hindered or where it could cause bodily injury.

**KEEP** the transceiver at least 3.3 ft (1 m) away from the ship's navigation compass.

**DO NOT** use or place the transceiver in areas with temperatures below  $-4^{\circ}\text{F}$  ( $-20^{\circ}\text{C}$ ) or above  $+140^{\circ}\text{F}$  ( $+60^{\circ}\text{C}$ ) or, in areas subject to direct sunlight, such as the dashboard.

**AVOID** the use of chemical agents such as benzine or alcohol when cleaning, as they may damage the transceiver surfaces.

**BE CAREFUL!** The transceiver rear panel will become hot when operating continuously for long periods.

Place the transceiver in a secure place to avoid inadvertent use by children.

After exposure to water including fresh water, clean the transceiver thoroughly with fresh water to avoid corrosion.

## ◇ PRIORITIES

- Read all rules and regulations pertaining to priorities and keep an up-to-date copy handy. Safety and distress calls take priority over all others.
- You must monitor channel 16 when you are not operating on another channel.
- False or fraudulent distress signals are prohibited and punishable by law.

## ◇ PRIVACY

- Information overheard but not intended for you cannot lawfully be used in any way.
- Indecent or profane language is prohibited.

## ◇ RADIO LICENSES

### (1) SHIP STATION LICENSE

You must have a current radio station license before using the transceiver. It is unlawful to operate a ship station which is not licensed.

Inquire through your dealer or the appropriate government agency for a Ship-Radiotelephone license application. This government-issued license states the call sign which is your craft's identification for radio purposes.

### (2) OPERATOR'S LICENSE

A Restricted Radiotelephone Operator Permit is the license most often held by small vessel radio operators when a radio is not required for safety purposes.

The Restricted Radiotelephone Operator Permit must be posted or kept with the operator. Only a licensed radio operator may operate a transceiver.

However, non-licensed individuals may talk over a transceiver if a licensed operator starts, supervises, ends the call and makes the necessary log entries.

Keep a copy of the current government rules and regulations handy.

## ■ Panel description

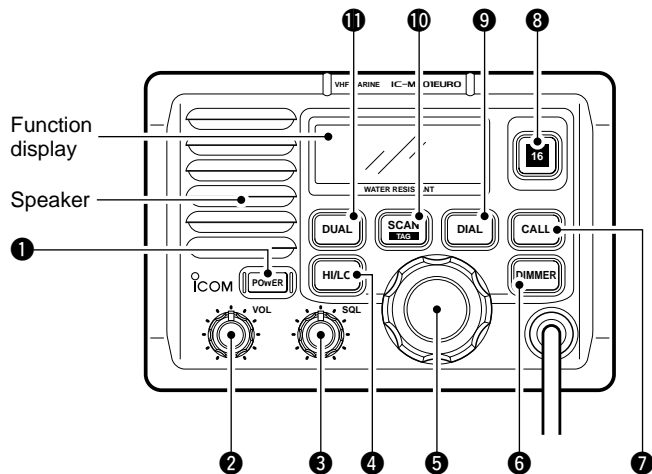

### ❶ POWER SWITCH [POWER]

Push to toggle the transceiver power ON and OFF.

### ❷ VOLUME CONTROL [VOL]

Adjusts the audio level. (p. 8)

### ❸ SQUELCH CONTROL [SQL]

Sets the squelch threshold level. (p. 8)

### ❹ TRANSMIT POWER SWITCH [HI/LO]

↳ Toggles high and low power when pushed. (p. 8)

• Some channels are set to low power only.

↳ While pushing this switch, other switches perform secondary functions.

**5 CHANNEL SELECTOR [CHANNEL]**

Rotate [CHANNEL] to select the operating channels, set mode contents, etc. (p. 8)

**6 DIMMER SWITCH [DIMMER]**

Push to select one of 8 backlighting (LCD and switches) levels.

**7 CALL CHANNEL SWITCH [CALL]**

- ➔ Push to select the call channel. (p. 6)
- ➔ Push for 3 sec. to enter call channel programming condition. (p. 9)
- ➔ While pushing [HI/LO], enters memory name programming condition. (p. 9)

**8 CHANNEL 16 SWITCH [16]**

- ➔ Selects channel 16 when pushed. (p. 6)
- ➔ Enters initial set mode when pushed while tuning power ON. (p. 14)

**9 DIAL SWITCH [DIAL]**

- ➔ Exits from channel 16 or call channel when pushed. (p. 6)
- ➔ While pushing [HI/LO], selects channel group when pushed. (pgs. 6, 7)
  - The European version has International channels only and this function is not available.

**10 SCAN SWITCH [SCAN/TAG] (p. 13)**

- ➔ Starts and stops normal or priority scan when tag channels are programmed.
- ➔ Push [SCAN/TAG] for 1 sec. to set the displayed channel as a tag (scanned) channel.
- ➔ While pushing [HI/LO], push for 3 sec. to clear all tag channels.

**11 DUALWATCH/TRI-WATCH SWITCH [DUAL] (p. 11)**

- ➔ Starts dualwatch or tri-watch when pushed.
- ➔ Stops dualwatch/tri-watch when either is activated.

## 2 PANEL DESCRIPTION

### ■ Function display

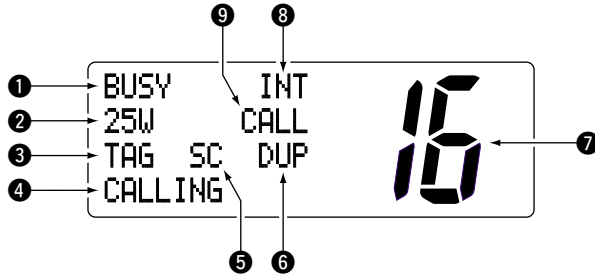

- 1 BUSY/TRANSMIT INDICATOR** (p. 8)
  - ↳ “BUSY” appears when receiving a signal or when the squelch opens.
  - ↳ “TX” appears while transmitting.
- 2 POWER INDICATOR** (p. 8)
  - ↳ “25W” appears when high power is selected.
  - ↳ “1W” appears when low power is selected.
- 3 TAG CHANNEL INDICATOR** (p. 13)

Appears when a tag channel is selected.

- 4 CHANNEL NAME INDICATOR**
  - ↳ Channel comment appears if programmed. (p. 9)
  - ↳ “Low Battery” appears when the battery voltage drops to approx. 10 V DC or below.
  - ↳ “DUAL” appears during dualwatch; “TRI” appears during tri-watch. (p. 11)
- 5 SCRAMBLER INDICATOR** (p. 11)

Appears when the optional voice scrambler is activated.
- 6 DUPLEX INDICATOR**

Appears when a duplex channel is selected.
- 7 CHANNEL NUMBER READOUT**
  - ↳ Indicates the selected operating channel number. “A” appears when a simplex channel is selected. (p. 6)
  - ↳ In set mode, indicates the selected condition. (p. 14)
- 8 CHANNEL GROUP INDICATOR** (p. 6)

Indicates whether an International, U.S.A., Holland, DSC or ATIS channel is selected.

  - Available channel groups depend on version.
- 9 CALL CHANNEL INDICATOR** (pgs. 6, 9)

Appears when a call channel is selected.



## ■ Microphone

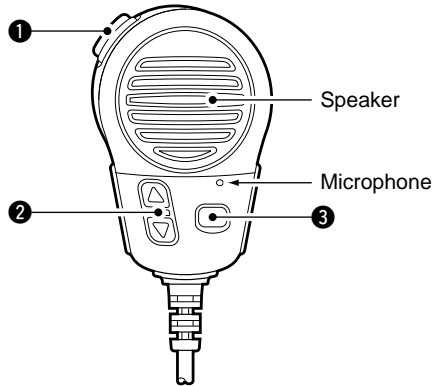

### ① PTT SWITCH [PTT]

Push and hold to transmit; release to receive. (p. 8)

### ② CHANNEL UP/DOWN SWITCHES [▲]/[▼]

Push either switch to change the operating memory channel, set mode contents, etc. (p. 8)

### ③ TRANSMIT POWER SWITCH [HI/LO]

➔ Same as the [HI/LO] switch on the front panel.

➔ Toggles the [▲]/[▼] and [HI/LO] switch functions ON and OFF when pushed at power ON.

## ■ Channel selection

### ◇ Channel 16

Channel 16 is the distress and safety channel. It is used for establishing initial contact with another station and for emergency communications. Channel 16 is monitored during both dualwatch and tri-watch. While standing by, you must monitor channel 16.

- ➔ Push [16] to select channel 16.
- ➔ Push [DIAL] to return to the condition before selecting channel 16, or rotate [CHANNEL] to select operating channel.

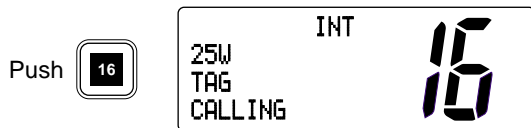

### ◇ Call channel

Each regular channel group has a separate leisure-use call channel. The call channel is monitored during tri-watch. The call channels can be programmed (p. 9) and are used to store your most often used channels in each channel group for quick recall.

- ➔ Push [CALL] to select the call channel of the selected channel group.
  - “CALL” and call channel number appear.
  - Each channel group may have an independent call channel after changing a call channel. (U.K. version only)
- ➔ Push [DIAL] to return to the condition before selecting call channel, or rotate [CHANNEL] to select operating channel.

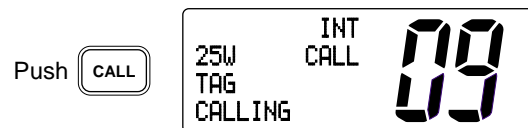

### ◇ International channels

There are 55 International channels for the IC-M501EURO.

- ① Push [DIAL] to select a regular channel.
- ② Push [DIAL] while pushing [HI/LO] to change the channel group, if necessary.
  - “INT” appears when International channels are selected.
- ③ Rotate the channel selector to select a channel.
  - “DUP” appears for duplex channels.

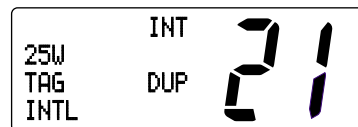

◆ **U.S.A. channels** (U.K. version only)

For the U.K. versions, there are 61 U.S.A. channels in addition to 56 International channels.

- ① Push [DIAL] to select a regular channel.
- ② To change the channel group, push [DIAL] while pushing [HI/LO].
  - International and U.S.A. channels can be selected in sequence.
- ③ Rotate the channel selector to select a channel.
  - Channels are memorized separately for each channel group.



◆ **Holland channels** (Holland version only)

For the holland versions, there are 57 Holland channels in addition to 56 International channels.

- ① Push [DIAL] to select a regular channel.
- ② To change the channel group, push [DIAL] while pushing [HI/LO].
  - International and Holland channels can be selected in sequence.
- ③ Rotate the channel selector to select a channel.
  - Channels are memorized separately for each channel group.



◆ **ATIS and DSC channels** (FRG version only)

For the FRG versions, there are 55 ATIS and 52 DSC channels in addition to 57 International channels.

- ① Push [DIAL] to select a regular channel.
- ② To change the channel group, push [DIAL] while pushing [HI/LO].
  - International, ATIS and DSC channels can be selected in sequence.
- ③ Rotate the channel selector to select a channel.
  - Channels are memorized separately for each channel group.



### 3 BASIC OPERATION

## ■ Receiving and transmitting

**CAUTION:** Transmitting without an antenna may damage the transceiver.

- 1 Push [POWER] to turn power ON.
- 2 Set the audio and squelch levels.
  - ➔ Rotate [SQL] fully counterclockwise in advance.
  - ➔ Rotate [VOL] to adjust the audio output level.
  - ➔ Rotate [SQL] clockwise until the noise disappears.
- 3 To change the channel group, push [DIAL] while pushing [HI/LO]. (p. 6)
  - The European version has International channels only.
- 4 Rotate the channel selector or push [▲]/[▼] on the microphone to select the desired channel.
  - When receiving a signal, “BUSY” appears and audio is emitted from the speaker.
  - Further adjustment of [VOL] may be necessary at this point.
  - Use the optional voice scrambler function for privacy. (p. 10)
- 5 Push [HI/LO] to select the output power if necessary.
  - “25W” or “1W” appears when high or low power is selected, respectively.
  - Choose low power to conserve power, choose high power for longer distance communications.
  - Some channels are for low power only.

- 6 Push and hold [PTT] to transmit, then speak into the microphone.
  - “TX” appears.
  - Channel 70 cannot be used for transmission (for GMDSS use).
- 7 Release [PTT] to receive.

**IMPORTANT:** To maximize the readability of your transmitted signal, pause a few sec. after pushing [PTT], hold the microphone 10 to 15 cm (4 to 6 inches) from your mouth and speak at a normal voice level.

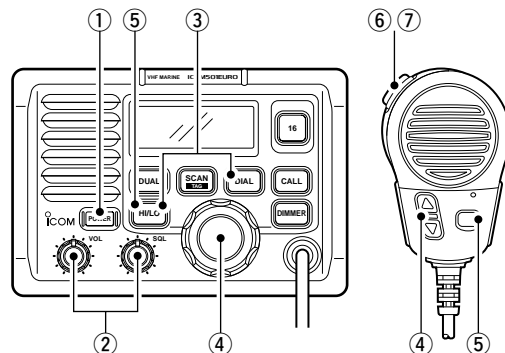

## ■ Call channel programming

The call channel switch can be programmed to your most often-used channels in each channel group for quick recall.

- ① While pushing [HI/LO], push [DIAL] one or more times to select the desired channel group (International, U.S.A., Holland, ATIS, DSC) to be programmed.
  - Channel number starts flashing.
- ② Push [CALL] for 3 sec. to enter the call channel programming condition.

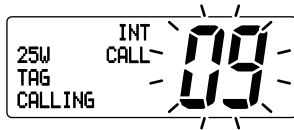

- ③ Rotate the channel selector to select the desired channel.

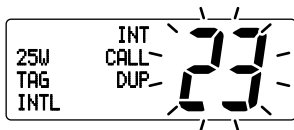

- ④ Push [CALL] to program the displayed channel as the call channel.
  - Push [DIAL] to cancel.
  - The channel number stops flashing.

## ■ Channel names

Memory channels can be tagged with alphanumeric names of up to 10 characters each.

Capital letters, small letters, numerals, some symbols (! " # \$ % & ' ( ) \* + , - . /) and spaces can be used.

- ① Select the desired memory channel.
  - Cancel dual watch, tri-watch or scan in advance.
- ② While pushing [HI/LO], push [CALL] to edit memory channel name.
  - A cursor appears and blinks.

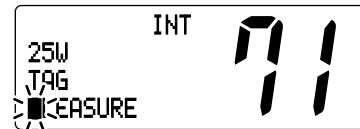

- ③ Select the desired character by rotating the channel selector or by pushing [▲]/[▼] on the microphone.
  - Push [SCAN] or [DIAL] for cursor movement.
- ④ Push [CALL] to input and set the name.
  - The cursor disappears.
- ⑤ Repeat steps ① to ④ to program another memory channel names, if desired.

### 3 BASIC OPERATION

## ■ Optional voice scrambler operation

### ◇ Activating the scrambler

The optional voice scrambler provides private communications. In order to receive or send scrambled transmissions you must first activate the scrambler function. To activate the function, an optional UT-98 or UT-112 is necessary. Ask your dealer for details.

- ① Select an operating channel except channel 16 and 70.
- ② While pushing [HI/LO], push [DIMMER] to toggle an optional scrambler function ON or OFF.
  - “SC” appears.
- ③ To turn the scrambler function OFF, repeat step ②.
  - “SC” disappears.

### ◇ Programming scrambler codes

There are 128 or 32 codes (0 to 127 or 1 to 32) available for programming. In order to understand one another, all transceivers in your group must have the same scramble code.

This function may not be available depending on dealer setting.

- ① Turn power OFF.
- ② While pushing [16], turn power ON to enter set mode.
- ③ After the display appears, release [16].
- ④ Push [16] one or more times to select the scrambler code item.
  - “Scrambler code” appears.
- ⑤ Rotate the channel selector to select the desired scrambler code.
- ⑥ Turn power OFF, then ON again to exit set mode.

**[Example]:** Programming scrambler code 127.

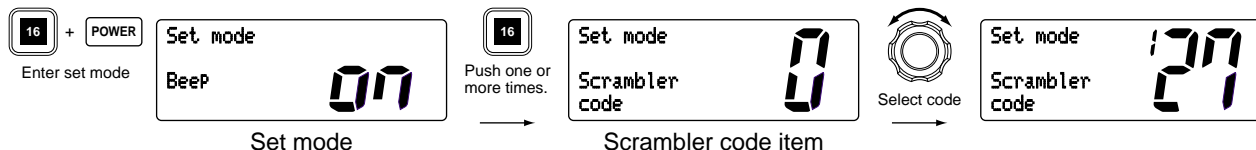

## ■ Description

Dualwatch monitors channel 16 while you are receiving another channel; tri-watch monitors channel 16 and the call channel while receiving another channel.

### DUALWATCH/TRI-WATCH SIMULATION

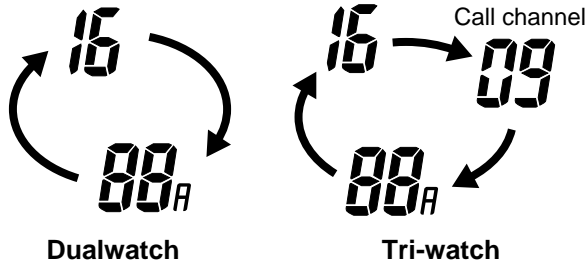

- If a signal is received on channel 16, dualwatch/tri-watch pauses on channel 16 until the signal disappears.
- If a signal is received on the call channel during tri-watch, tri-watch becomes dualwatch until the signal disappears.
- To transmit on the selected channel during dualwatch/tri-watch, push and hold [PTT].

## ■ Operation

- ① Select the desired operating channel.
- ② Select dualwatch or tri-watch in set mode. (p. 15)
- ③ Push [DUAL] to start dualwatch or tri-watch.
  - “DUAL” appears during dualwatch; “TRI” appears during tri-watch.
  - Beep tone sounds when a signal is received on channel 16.
  - Tri-watch becomes dualwatch when receiving a signal on the call channel.
- ④ To cancel dualwatch/tri-watch, push [DUAL] again.

**[Example]:** Operating tri-watch on INT channel 25.

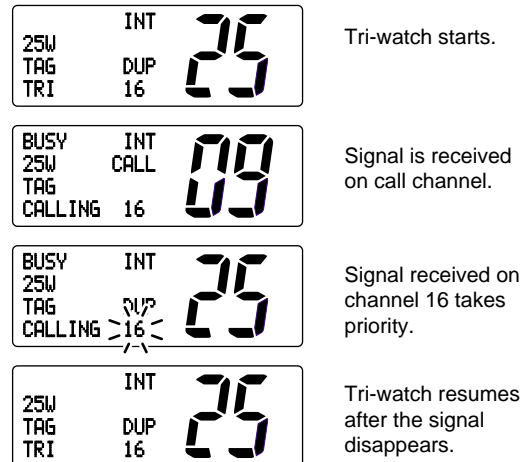

## ■ Scan types

Scanning is an efficient way to locate signals quickly over a wide frequency range. The transceiver has priority scan and normal scan.

Set the tag channels (scanned channel) before scanning. Clear the tag channels which inconveniently stop scanning, such as digital communication use.

/// Choose priority or normal scan in set mode. (p. 15)

### PRIORITY SCAN

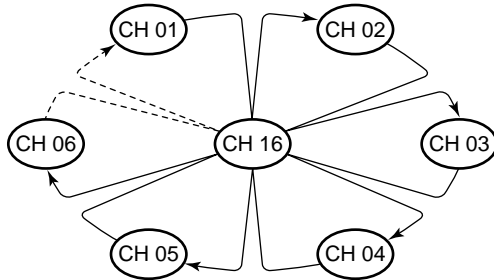

Priority scan searches through all tag channels in sequence while monitoring channel 16. When a signal is detected on channel 16, scan pauses until the signal disappears; when a signal is detected on a channel other than channel 16, scan becomes dualwatch until the signal disappears.

### NORMAL SCAN

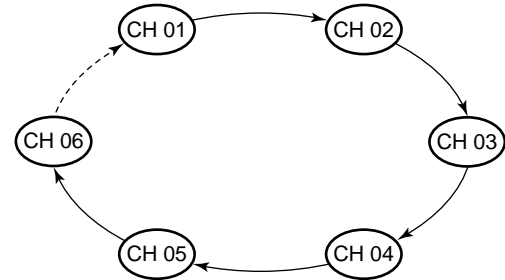

Normal scan, like priority scan, searches through all tag channels in sequence. However, unlike priority scan, channel 16 is not checked unless channel 16 is set as a tag channel.



## ■ Setting tag channels

For more efficient scanning, add desired channels as tag channels or clear tag channels for unwanted channels. Channels set as non-tag channels will be skipped during scanning. Tag channels can be assigned to each channel group (International, U.S.A., Holland, DSC, ATIS) independently.

- ① While pushing [HI/LO], push [DIAL] one or more times to select the desired channel group, if desired.
- ② Select the desired channel to set as a tag channel.
- ③ Push [SCAN/TAG] for 1 sec. to set the displayed channel as a tag channel.
  - “TAG” appears in the function display.
- ④ To cancel the tag channel setting, repeat ③.
  - “TAG” disappears.

### •Clearing all tag channels in the selected channel group

- While pushing [HI/LO], push [DIAL] for 3 sec. to clear all tag channels in the channel group.

## ■ Starting a scan

Set scan type (priority or normal scan) and scan resume timer in advance using set mode. (p. 15)

- ① Set tag channels as described at left.
- ② While pushing [HI/LO], push [DIAL] one or more times to select the desired channel group, if desired.
- ③ Push [SCAN] to start priority or normal scan.
  - “Pri scan 16” or “Normal scan” appears in the function display.
  - When a signal is detected, scan pauses until the signal disappears or resumes after pausing 5 sec. according to set mode setting. (Channel 16 is still monitored during priority scan.)
  - Rotate the channel selector to check the scanning tag channels, to change the scanning direction or resume the scan manually.
  - “16” flashes and a beep tone sounds when a signal is received on channel 16 during priority scan.
- ④ To stop the scan, push [SCAN].
  - “Pri scan” or “Normal scan” disappears.

**[Example]:** Starting a normal scan.

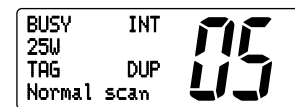
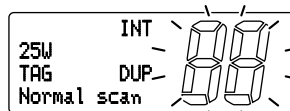
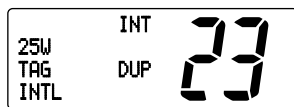

## ■ Set mode programming

Set mode is used to change the conditions of the transceiver's functions: beep tone function, scan mode (normal/priority), scan resume timer, dual/tri watch, LCD contrast, scramble code, scrambler unit, internal speaker and ATIS code.

▨ Available functions may differ depending on versions.

- ① Turn power OFF.
- ② While pushing [16], turn power ON to enter set mode.
- ③ After the display appears, release [16].
- ④ Push [16] to select the desired item, if necessary.
- ⑤ Rotate the channel selector to select the desired condition of the item.
- ⑥ Turn power OFF, then ON again to exit set mode.

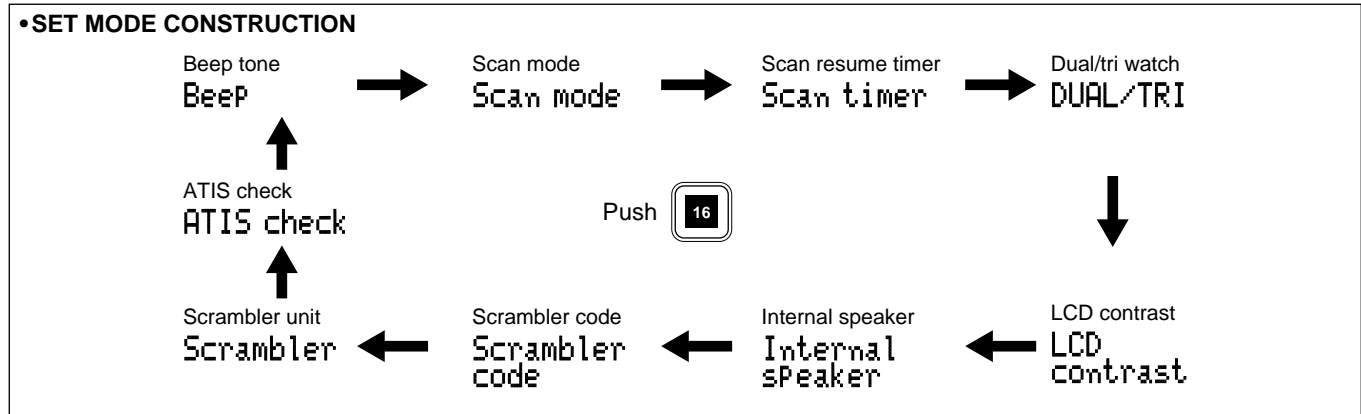

## ■ Set mode items

### ◇ Beep tone

You can select silent operation by turning beep tones OFF or you can have confirmation beeps sound at the push of a switch by turning beep tones ON.

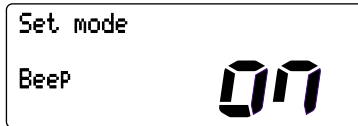

Beep tone ON (default)



Beep tone OFF

### ◇ Scan mode

The transceiver has 2 scan modes: normal scan and priority scan. Normal scan searches all tag channels in the selected channel group. Priority scan searches all tag channels in sequence while monitoring channel 16.



Priority scan (default)



Normal scan

### ◇ Scan resume timer

The scan resume timer can be selected as a pause (OFF) or timer scan (ON). When OFF is selected, the scan pauses until the signal disappears. When ON is selected, the scan pauses 5 sec. and resumes even if a signal is being received on channels except for channel 16.



Scan timer ON (default)



Scan timer OFF

### ◇ Dual/tri watch

This item sets the [DUAL] switch function as dual watch or tri-watch.

See the section 'Dual watch/Tri-watch' for details.

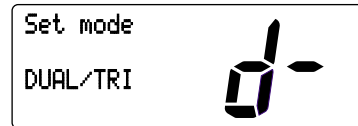

Dual watch (default)

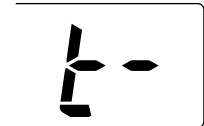

Tri-watch

## 6 SET MODE

### ◆ LCD contrast

This item adjusts the contrast of the LCD in 8 steps.

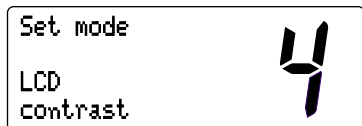

LCD contrast 4 (default)

### ◆ Internal speaker

When an optional external speaker is connected, the speakers on the transceiver and microphone can be muted.



Internal speaker ON (default)

Internal speaker OFF

### ◆ Scrambler code

When an optional scrambler unit is connected, the scrambler code can be set depending on dealer setting.

When the UT-98 or UT-112 is installed, 128 or 32 codes (0 to 127 or 1 to 32) can be selected, respectively.



Scrambler code 0 (UT-98 default)

Scrambler code 127

### ◆ Scrambler unit

When an optional scrambler unit is connected, the scrambler unit can be selected in set mode depending on dealer setting.



UT-98 scrambler unit

UT-112 scrambler unit

### ◆ ATIS check

The ATIS ID code can be checked in set mode.

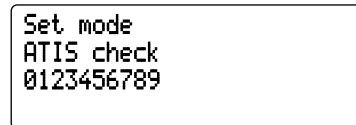

ATIS code

## ■ Unpacking

The following accessories are supplied: Qty.

- ① Mounting bracket ..... 1
- ② Microphone hanger (OPC-562) ..... 1
- ③ Mic hanger screws (3.5 × 30) ..... 2
- ④ Mounting screws (5 × 20) ..... 2
- ⑤ Flat washers (M5) ..... 2
- ⑥ Spring washers (M5) ..... 2
- ⑦ Mounting bracket knobs ..... 2
- ⑧ DC power cable (OPC-947) ..... 1

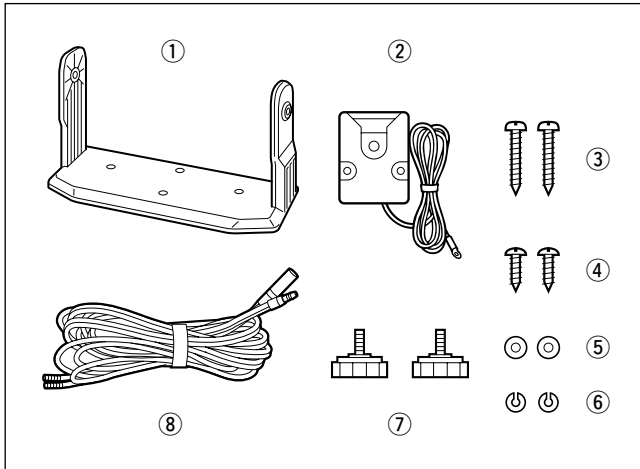

## ■ Antenna

A key element in the performance of any communication system is an antenna. Ask your dealer about antennas and the best places to mount them.

## ■ Fuse replacement

Two fuses are installed in the supplied DC power cable. If a fuse blows or the transceiver stops functioning, track down the source of the problem, if possible, and replace the damaged fuse with a new, rated one.

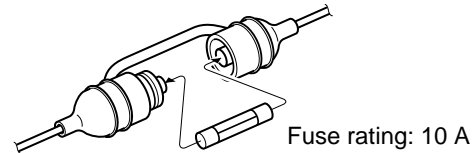

## ■ Cleaning

If the transceiver becomes dusty or dirty, wipe it clean with a soft, dry cloth.



**AVOID** the use of solvents such as benzene or alcohol, as they may damage transceiver surfaces.

## 7 CONNECTIONS AND MAINTENANCE

### ■ Connections

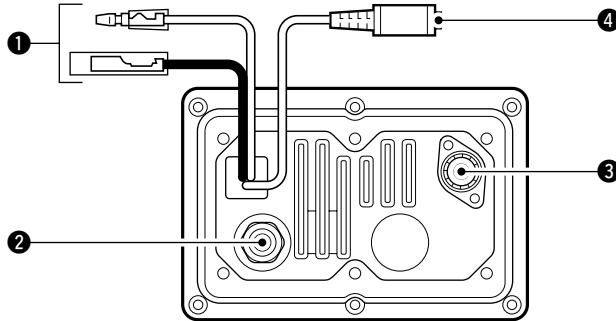

#### ① DC POWER CONNECTOR

Connects the supplied DC power cable from this connector to an external 12 V DC power source.

**CAUTION:** After connecting the DC power cable and external speaker jack, cover the connector and jack as shown below to avoid water seeping into the transceiver.

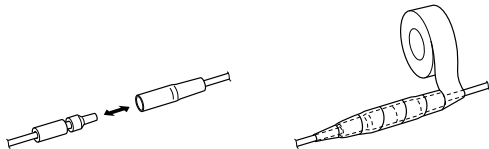

#### ② EXTENSION JACK

Connects to optional DS-100 DSC CONTROLLER or OPC-979 ADAPTER CABLE.

#### ③ ANTENNA CONNECTOR

Connects a marine VHF antenna with a PL-259 connector to the transceiver.

**CAUTION:** Transmitting without an antenna may damage the transceiver.

#### ④ EXTERNAL SPEAKER JACK

Connects to an external speaker. See 'Options' on p. 25 for available external speakers.

#### MICROPHONE HANGER

Rest the supplied microphone on the hanger when not in use.

## ■ Mounting the transceiver

### ◆ Using the supplied mounting bracket

The universal mounting bracket supplied with your transceiver allows overhead or dashboard mounting.

- Mount the transceiver securely with the 2 supplied screws (M5 × 20) to a surface which is more than 10 mm thick and can support more than 5 kg.
- Mount the transceiver so that the face of the transceiver is at 90° to your line of sight when operating it.

/// **CAUTION: KEEP** the transceiver and microphone at least 1 meter away from your vessel's magnetic navigation compass.

/// **NOTE:** Check the installation angle; the function display may not be easy-to-read at some angles.

### • OVERHEAD MOUNTING

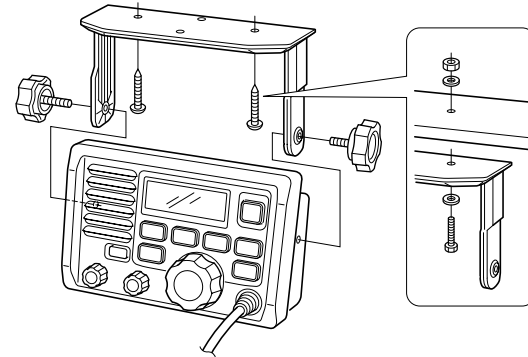

### • MOUNTING ON DASHBOARD

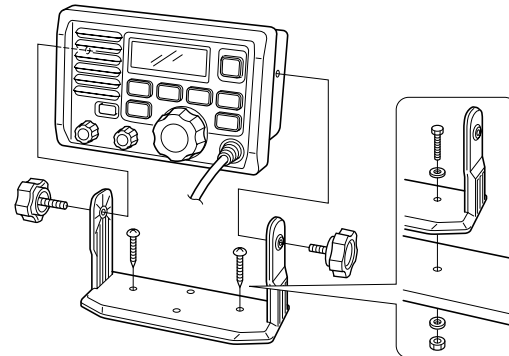

## 7 CONNECTIONS AND MAINTENANCE

### ◆ Using the optional mounting bracket

An optional MB-75 FLUSH MOUNT is available for mounting the transceiver to a flat surface such as an instrument panel.

**CAUTION:** KEEP the transceiver and microphone at least 1 meter away from your vessel's magnetic navigation compass.

- ① Using the template on the last page, carefully cut a hole into the instrument panel (or wherever you plan to mount the controller).
- ② Slide the controller through the hole, rear panel first.

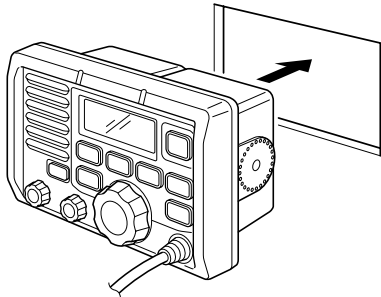

- ③ Using the 2 supplied bolts (M5 × 8 mm), attach the clamps on either side of the IC-M501 as shown below.
  - Make sure that the clamps align parallel to the IC-M501's body.

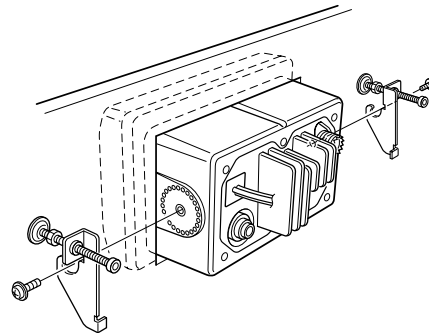

- ④ Tighten the end bolts on the clamps (rotate clockwise) so that the clamps press firmly against the inside of the instrument control panel.
- ⑤ Tighten the locking nuts (rotate counterclockwise) so that the IC-M501 is securely mounted in position as below.
- ⑥ Connect the antenna and control cable, then return the instrument control panel to its original place.

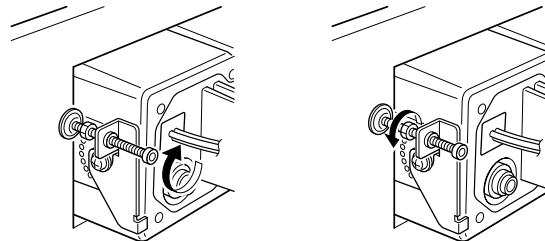



## ■ Optional unit installation

**CAUTION: DISCONNECT** the DC power cable from the transceiver before performing any work on the transceiver. Otherwise, there is danger of electric shock and/or equipment damage.

### ◆ Opening the transceiver case

Follow the case opening procedure shown here when you want to install an optional unit, etc.

- ① Remove the 6 screws as shown below and open the transceiver.

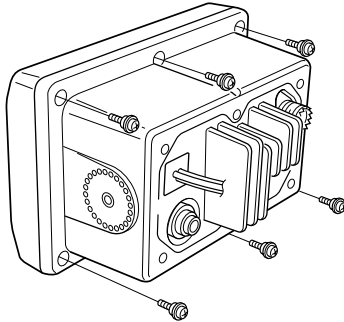

- ② Remove the 4 screws from the shielding plate, then lift up the shielding plate.
- ③ Plug an optional unit to J6 on the MAIN unit as shown below.

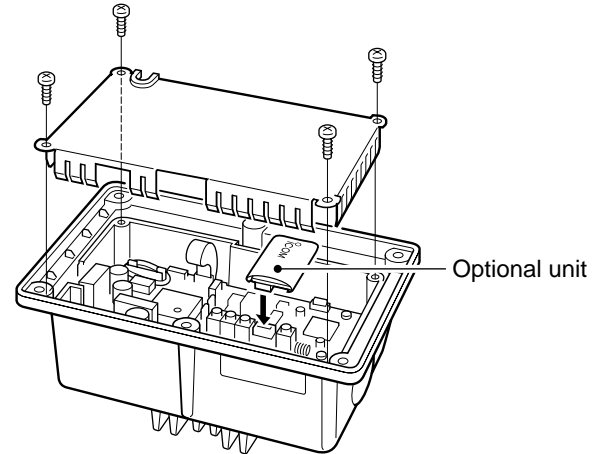

- ④ Return the shielding plate and assemble the units to their original positions.

## ■ Dimensions

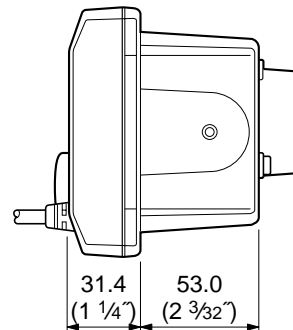
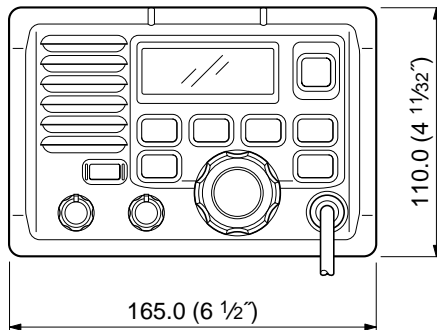
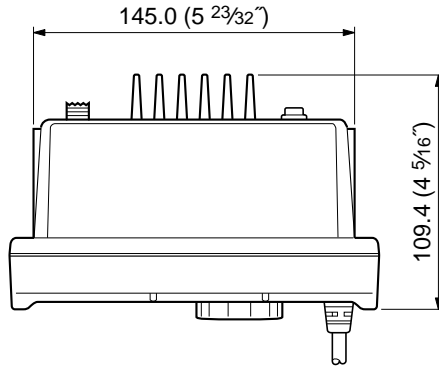

Unit: mm (inch)

PROBLEM	POSSIBLE CAUSE	SOLUTION	REF.
No power comes ON.	<ul style="list-style-type: none"> <li>•Bad connection to the power supply.</li> </ul>	<ul style="list-style-type: none"> <li>•Check the connection to the transceiver.</li> </ul>	p. 18
No sound comes from the speaker.	<ul style="list-style-type: none"> <li>•Squelch level is too deep.</li> <li>•Volume level is too low.</li> <li>•Speaker has been exposed to water.</li> </ul>	<ul style="list-style-type: none"> <li>•Set squelch to the threshold point.</li> <li>•Set [VOL] to a suitable level.</li> <li>•Drain water from the speaker.</li> </ul>	<p>p. 8</p> <p>p. 8</p> <p>—</p>
Transmitting is impossible, or high power cannot be selected.	<ul style="list-style-type: none"> <li>•Some channels are for low power or receive only.</li> <li>•The output power is set to low.</li> </ul>	<ul style="list-style-type: none"> <li>•Change channels.</li> <li>•Push [HI/LO] to select high power.</li> </ul>	<p>pgs. 6, 24</p> <p>p. 8</p>
Scan does not start.	<ul style="list-style-type: none"> <li>•“TAG” channel is not programmed.</li> </ul>	<ul style="list-style-type: none"> <li>•Set the desired channels as “TAG” channels.</li> </ul>	p. 13
No beep sounds.	<ul style="list-style-type: none"> <li>•Beep tone is turned OFF.</li> </ul>	<ul style="list-style-type: none"> <li>•Turn the beep tone ON in SET mode.</li> </ul>	p. 15
Receive signal cannot be understood.	<ul style="list-style-type: none"> <li>•Optional voice scrambler is turned OFF.</li> <li>•Scramble code is not set correctly.</li> </ul>	<ul style="list-style-type: none"> <li>•Turn the optional voice scrambler ON.</li> <li>•Reset the scramble code.</li> </ul>	<p>p. 10</p> <p>p. 16</p>

## • International channels

CH	Frequency (MHz)		CH	Frequency (MHz)		CH	Frequency (MHz)		CH	Frequency (MHz)		CH	Frequency (MHz)		CH	Frequency (MHz)	
	Transmit	Receive		Transmit	Receive		Transmit	Receive		Transmit	Receive		Transmit	Receive		Transmit	Receive
01	156.050	160.650	11	156.550	156.550	21	157.050	161.650	62	156.125	160.725	72	156.625	156.625	84	157.225	161.825
02	156.100	160.700	12	156.600	156.600	22	157.100	161.700	63	156.175	160.775	73	156.675	156.675	85	157.275	161.875
03	156.150	160.750	13	156.650	156.650	23	157.150	161.750	64	156.225	160.825	74	156.725	156.725	86	157.325	161.925
04	156.200	160.800	14	156.700	156.700	24	157.200	161.800	65	156.275	160.875	77	156.875	156.875	87	157.375	161.975
05	156.250	160.850	15†	156.750	156.750	25	157.250	161.850	66	156.325	160.925	78	156.925	161.525	88	157.425	162.025
06	156.300	156.300	16	156.800	156.800	26	157.300	161.900	67	156.375	156.375	79	156.975	161.575			
07	156.350	160.950	17†	156.850	156.850	27	157.350	161.950	68	156.425	156.425	80	157.025	161.625			
08	156.400	156.400	18	156.900	161.500	28	157.400	162.000	69	156.475	156.475	81	157.075	161.675			
09	156.450	156.450	19	156.950	161.550	60	156.025	160.625	70†	156.525	156.525	82	157.125	161.725			
10	156.500	156.500	20	157.000	161.600	61	156.075	160.675	71	156.575	156.575	83	157.175	161.775			

## • U.S.A. channels (for U.K. version only)

CH	Frequency (MHz)		CH	Frequency (MHz)		CH	Frequency (MHz)		CH	Frequency (MHz)		CH	Frequency (MHz)		CH	Frequency (MHz)	
	Transmit	Receive		Transmit	Receive		Transmit	Receive		Transmit	Receive		Transmit	Receive		Transmit	Receive
01A	156.050	156.050	11	156.550	156.550	20A	157.000	157.000	61A	156.075	156.075	71	156.575	156.575	83A	157.175	157.175
02A	156.100	156.100	12	156.600	156.600	21A	157.050	157.050	62A	156.125	156.125	72	156.625	156.625	84	157.225	161.825
03A	156.150	156.150	13†	156.650	156.650	22A	157.100	157.100	63A	156.175	156.175	73	156.675	156.675	85	157.275	161.875
04A	156.200	156.200	14	156.700	156.700	23A	157.150	157.150	64A	156.225	156.225	74	156.725	156.725	86	157.325	161.925
05A	156.250	156.250	15‡	156.750	156.750	24	157.200	161.800	65A	156.275	156.275	77	156.875	156.875	86A	157.325	157.325
06	156.300	156.300	16	156.800	156.800	25	157.250	161.850	66A	156.325	156.325	78A	156.925	156.925	87	157.375	161.975
07A	156.350	156.350	17†	156.850	156.850	26	157.300	161.900	67†	156.375	156.375	79A	156.975	156.975	88	157.425	162.025
08	156.400	156.400	18A	156.900	156.900	27	157.350	161.950	68	156.425	156.425	80A	157.025	157.025	88A	157.425	157.425
09	156.450	156.450	19A	156.950	156.950	28	157.400	162.000	69	156.475	156.475	81A	157.075	157.075			
10	156.500	156.500	20	157.000	161.600	60A	156.025	156.025	70‡	156.525	156.525	82A	157.125	157.125			

† Low power only for U.K. version.

‡ Receive only.

## ■ Specifications

### •GENERAL

- Frequency coverage :
  - Transmit 156.025–157.425 MHz
  - Receive 156.025–162.025 MHz
- Mode : FM (16K0G3E)
- Channel spacing : 25 kHz
- Current drain (at 13.8 V) : TX high 6.0 A max.  
Max. audio 1.2 A max.
- Power supply requirement : 13.8 V DC
- Frequency stability : ±10 ppm  
(–20°C to +60°C; –4°F to +140°F)
- Dimensions : 165(W)×110(H)×109.4(D) mm  
(Projection not included)
- Weight : 1130 g

### •TRANSMITTER

- Output power : 25 W and 1 W
- Modulation system : Variable reactance phase modulation
- Max. frequency deviation : ±5.0 kHz
- Spurious emissions : Less than 0.25 µW

### •RECEIVER

- Receive system : Double conversion superheterodyne
- Sensitivity (12 dB SINAD) : Less than 0.32 µV (typical)
- Squelch sensitivity : Less than 0.32 µV
- Intermodulation rejection ratio : More than 68 dB
- Spurious response rejection ratio : More than 70 dB
- Adjacent channel selectivity : More than 70 dB
- Audio output power : 3.5 W at 10% distortion with a 4 Ω load

## ■ Options

### •DS-100 DSC CONTROLLER

When the DS-100 is installed, the transceiver conforms to DSC class D for marine digital communications.

### •MB-75 FLUSH MOUNT

For mounting the transceiver to a panel.

### •SP-5 EXTERNAL SPEAKER

A large, external speaker for superior audio output.

### •SP-10 EXTERNAL SPEAKER

A compact, external speaker. Features easy installation.

### •CS-M501 CLONING SOFTWARE + OPC-478 CLONING CABLE + OPC-979 ADAPTER CABLE

Allows you to transfer data from memories, etc. and quickly and easily edit and store data via a PC (for Microsoft® Windows® 95 and 98).

### •UT-98 VOICE SCRAMBLER UNIT

### •UT-112 VOICE SCRAMBLER UNIT

Ensures private communications. 128 or 32 codes are available. Not available in some countries.

**All stated specifications are subject to change without notice or obligation.**

Microsoft® and Windows® are registered trademarks of Microsoft Corporation in the U.S.A and other countries.

# MB-75 TEMPLATE

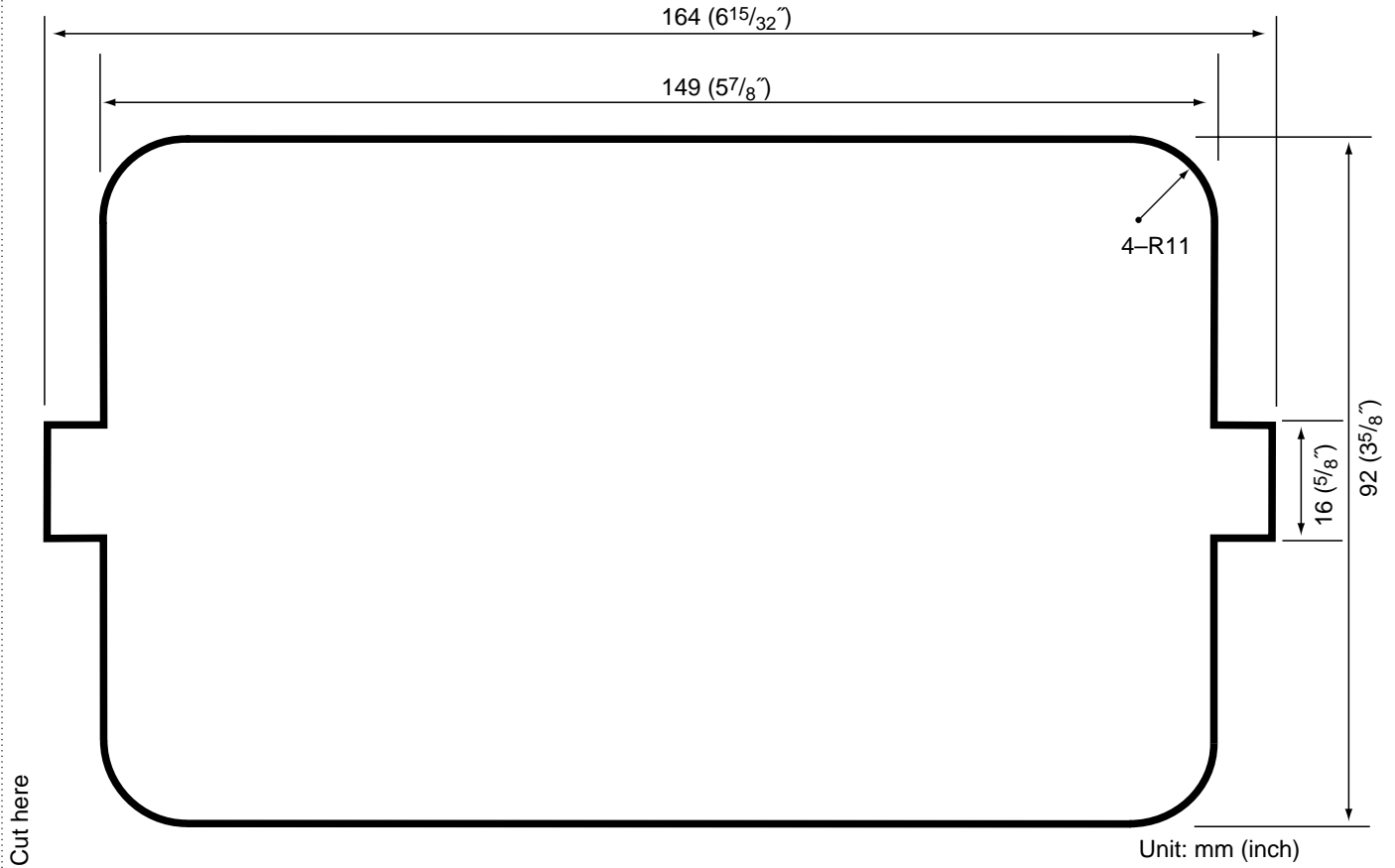



## DECLARATION OF CONFORMITY

We Icom Inc. Japan  
6-9-16, Kamihigashi, Hirano-ku  
Osaka 547-0002, Japan

CE 0560 !

Declare on our sole responsibility that this equipment complies the essential requirements of the Radio and Telecommunications Terminal Equipment Directive, 1999/5/CE, and that any applicable Essential Test Suite measurements have been performed.

Düsseldorf 10th Apr. 2000

Place and date of issue

**Kind of equipment:** VHF MARINE TRANSCEIVER

**Type-designation:** IC-M501EURO

Icom (Europe) GmbH  
Himmelgeister straÙe 100  
D-40225 Düsseldorf

Authorized representative name

**Version (where applicable):**

This compliances is based on conformity with the following harmonised standards, specifications or documents:

- i) EN 301 025-2 V0.1.2 (2000-02)
- ii) prETS 300 162 2nd Edition December 1997
- iii) EN 60945 1997
- iv) prETS 300 698 December 1996
- v) \_\_\_\_\_

Icom (Europe) GmbH

T. Aoki  
General Manager

Signature

**Icom Inc.**

**Count on us!**

**< Intended Country of Use >**

■ GER	■ NED	■ ITA
■ AUT	■ BEL	■ GRE
■ GBR	■ LUX	■ SWE
■ IRL	■ ESP	■ DEN
■ FRA	■ POR	■ FIN